

Technical data sheet

Product features



Box + evaporator for INFINITY 2011

Model	SAP Code	00012530
--------------	-----------------	----------



- Shock cooling cycle kg / min (+3 Å° C): 110/90
- Shock freeze cycle kg / min (-18 Å° C): 95/240
- Probe: 4-points
- Insulation thickness [mm]: 80
- Control type: Touchscreen
- Display size: 9"
- User programmable cycles: Yes, with save options
- Thaving cycle: Yes
- Proving cycle: Yes

SAP Code	00012530	Loading	400 V / 3N - 50 Hz
Net Width [mm]	1190	Number of GN / EN	20
Net Depth [mm]	1332	GN / EN size in device	GN 1/1
Net Height [mm]	2490	Shock cooling cycle kg / min (+3 Å° C)	110/90
Net Weight [kg]	518.00	Shock freeze cycle kg / min (-18 Å° C)	95/240
Power electric [kW]	3.250	Control type	Touchscreen

Technical data sheet

Technical drawing



Box + evaporator for INFINITY 2011

Model

SAP Code

00012530

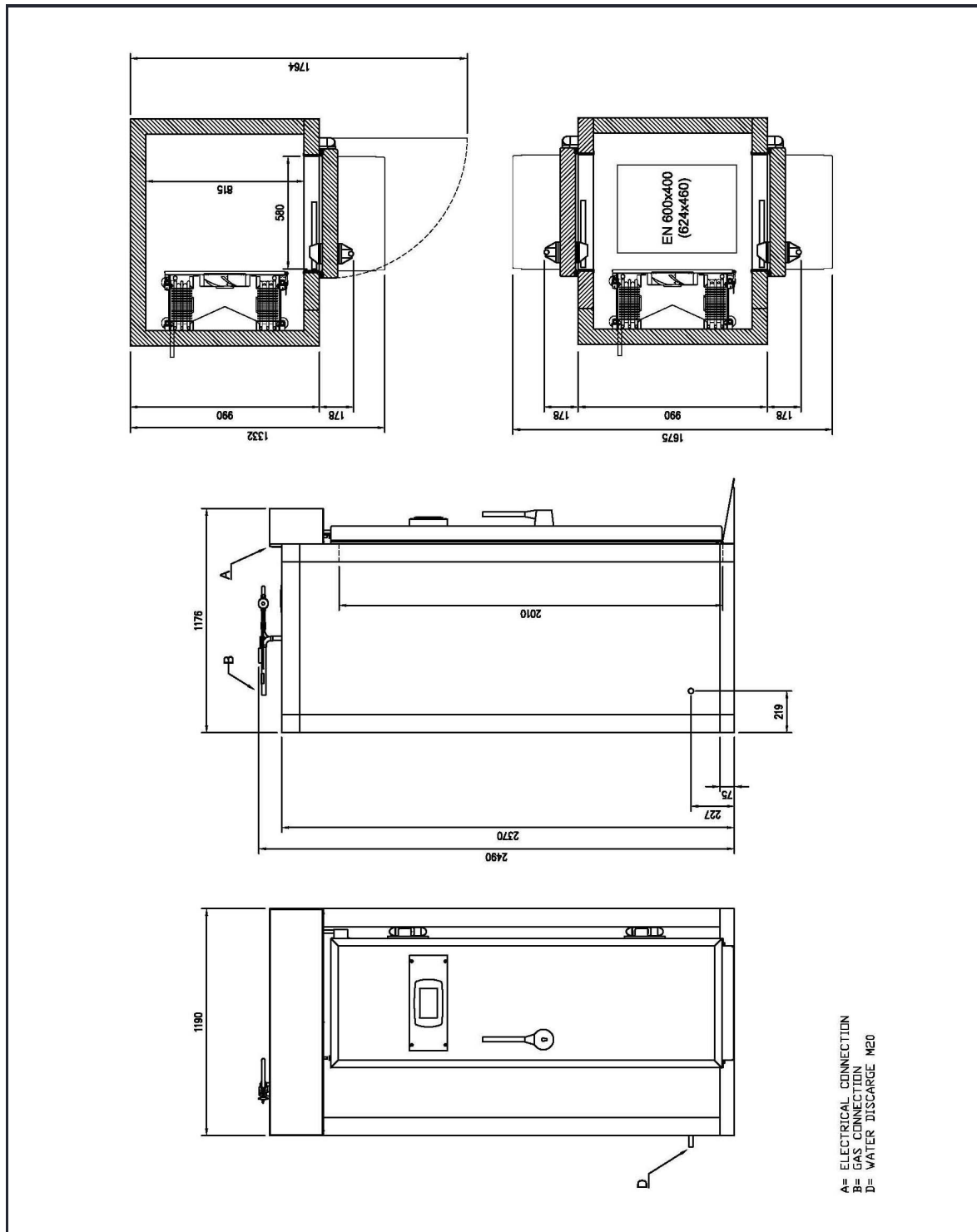

Technical data sheet

Product benefits



Box + evaporator for INFINITY 2011

Model

SAP Code

00012530

1

6 in 1

can replace 6 devices (fridge, freezer, shocker, hotbox, kitchen, oven)

- saves space, time, energy and the cost of additional equipment due to the enormous variability

2

Stainless steel body and interior

endurance
hygiene

- thanks to the all-stainless steel construction it is very easy to maintain and thus saves costs

3

Monitoring of HACCP parameters

easy registration of all necessary parameters

- hassle-free proof of proper food handling in the event of an inspection

4

Preset cycles

very simple and intuitive operation

- operation can be handled by less qualified operators

5

Multipoint probe

precise monitoring of the cooling/freezing/
cooking temperature

- the probe makes it easier to ensure food safety
- saves energy and time due to the end of cooling/freezing/cooking when temperature is reached

6

Thawing

readiness of frozen food for processing on time

- time saving
- controlled food handling

7

Cooking during the night

the possibility to preset entire program cycles and run them overnight unattended

- saving equipment capacity during the day
- saving of human capacity and time due to unattended operation of the equipment overnight

Technical data sheet

Technical parameters



Box + evaporator for INFINITY 2011

Model

SAP Code

00012530

1. SAP Code:

00012530

2. Net Width [mm]:

1190

3. Net Depth [mm]:

1332

4. Net Height [mm]:

2490

5. Net Weight [kg]:

518.00

6. Gross Width [mm]:

1110

7. Gross depth [mm]:

2310

8. Gross Height [mm]:

900

9. Gross Weight [kg]:

538.00

10. Device type:

Electric unit

11. Material:

AISI 304

12. Device color:

Stainless steel

13. Power electric [kW]:

3.250

14. Loading:

400 V / 3N - 50 Hz

15. Control type:

Touchscreen

16. Display size:

9"

17. Refrigerant:

R452a

18. Number of GN / EN:

20

19. GN / EN size in device:

GN 1/1

20. Shock freeze cycle kg / min (-18 Å° C):

95/240

21. Shock cooling cycle kg / min (+3 Å° C):

110/90

22. Insulation thickness [mm]:

80

23. Long-term cooling function:

Yes

24. Longterm freezing function:

Yes

25. Probe:

4-points

26. Self-diagnostics:

Yes

27. HACCP:

Yes

28. Low temperature heat treatment:

Yes

Technical data sheet

Technical parameters



Box + evaporator for INFINITY 2011

Model	SAP Code	00012530
--------------	-----------------	----------

29. Low temperature cooking span:

52-85

30. Thaving cycle:

Yes

31. Proving cycle:

Yes

32. User programmable cycles:

Yes, with save options

33. USB port:

Yes, for HACCP and firmware update

34. Castors:

No

35. Real time monitoring paramaters:

Energy consumption, Chamber temperature, Probe temperature, Graph with the course of temperature and consumption